

**Catalogue**  
*Innovation is our impetus*



**The detail makes the difference**  
Latest technology for highest precision.

**2017**  
**2018**



AKE is a family-run, medium-sized company with international orientation. Our position offers decisive advantages to our customers. They meet the versatility and competence of a big company and take advantage of the promptness and flexibility of a small firm. Our specialisation, the proverbial precision, the innovative approach and a huge wealth of experience help our customers to gain the top.

For more than 50 years AKE has been standing for highest quality in industry and crafts. AKE today – is one of the leading manufacturers of circular saw blades and cutting tools worldwide.

**Whether individual tools or demanding standards are required: the solution is always AKE.**

***„Think global - act local“***  
*The company of great tradition - AKE*



**AKE**  
Cutting & better  
DIAMOND

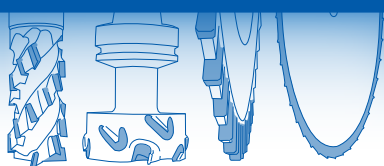

# *Cutter with bore*

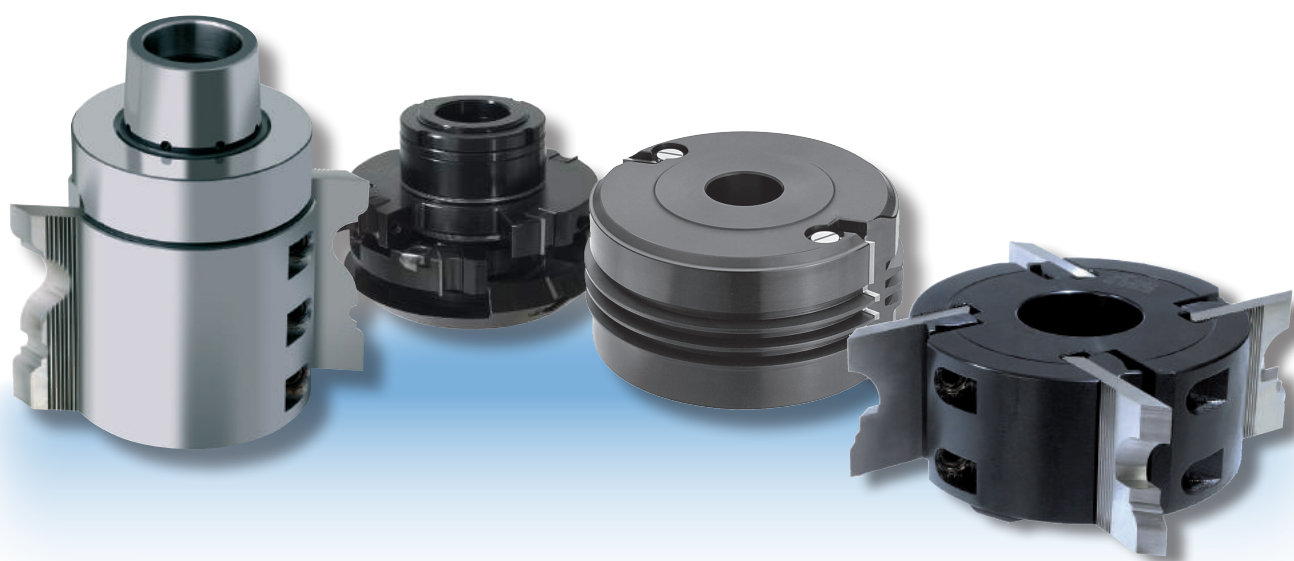

## Content

## Cutter with bore

Products	Page
Planing cutter head .....	144-148
Bevel cutter .....	149-150
Rebate cutter.....	151
Grooving cutter.....	152-160
Radius cutter.....	161
Profile cutter .....	162-168
Panel raising cutter .....	169
Glue joint cutter .....	170
Edge trimming cutter .....	171

## Planing cutter head

### Planing cutter head with clamping wedge



<b>APPLICATION:</b>	For pre and finish planing
<b>MATERIAL:</b>	Hard and soft wood
<b>MACHINE:</b>	Four-sided profile cutting and planing machine
<b>DESIGN:</b>	Steel cutter head re-sharpenable HS planer knives 30x3 mm. HW planer knives can be ordered separately.
<b>TOOTH:</b>	HS

**33030**

#### Steel tool body

D mm	B mm	d mm	d (max) mm	Z	Order No.
125	80	30	40	4	10156831
125	100	30	40	4	10156835
125	130	30	40	4	10156836
125	150	30	40	4	10156840
125	180	30	40	4	10156837
125	220	30	40	4	10156838
125	230	30	40	4	10156839

Further dimensions on demand.  
Available with HW planer knives at a premium.

#### Spare parts

Denomination	Dimension mm	DT	Order No.
Clamping wedge	80x21,7x12	◇	10157182
Clamping wedge	100x21,7x12	◇	10157183
Clamping wedge	130x21,7x12	◇	10157222
Clamping wedge	150x21,7x12	◇	10157223
Clamping wedge	180x21,7x12	◇	10157336
Clamping wedge	220x21,7x12	◇	10157227
Clamping wedge	230x21,7x12	◇	10157335
Screw	M10x25	◇	10160236
Key	SW5	◇	10160237

## Planing cutter head

### Hydraulic planing cutter head with clamping wedge

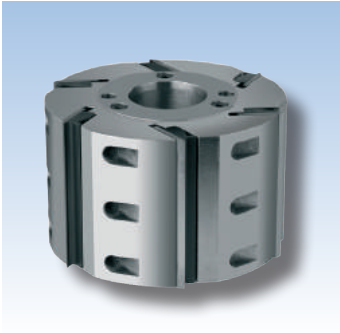

<b>APPLICATION:</b>	For super finish planing, chip removal 0.5 - 0.8 mm
<b>MATERIAL:</b>	Hard and soft wood
<b>DESIGN:</b>	Steel body, planer knife 30x3 mm.
<b>TOOTH:</b>	HS
<b>FEED:</b>	MEC

**33030**

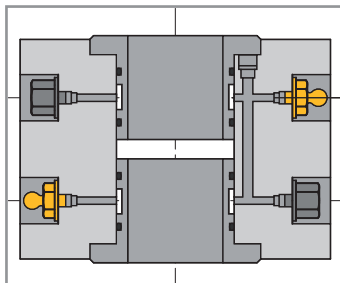

#### Steel tool body with HS knives

D mm	B mm	d mm	Z	n (max) min <sup>-1</sup>	DT	Order No.
143	150	40	6	9.000	◇	10156775
163	100	50	6	8.000	◇	10156777
163	150	50	6	8.000	◇	10156780
163	150	50	8	8.000	◇	10156781

Further dimensions on demand.  
HS knives in the scope of delivery. Not mounted.

#### Spare parts

Denomination	Dimension mm	DT	Order No.
Clamping wedge	100x21,7x12	◇	10157183
Clamping wedge	150x21,7x12	◇	10157223
Threaded pin	M12x20	◇	10157171
Sliding bar key	SW6	◇	40005681

## Planing cutter head

With centrifugal clamping



<b>APPLICATION:</b>	For pre and finish planing
<b>MATERIAL:</b>	Hard and soft wood
<b>DESIGN:</b>	Steel body with TOK n (min) 6.000 rpm / n (max) 10.000 rpm
<b>TOOTH:</b>	HS TOK system Centrolock
<b>FEED:</b>	MEC

# 33030

D mm	B mm	d mm	Z	n (max) min <sup>-1</sup>	DT	Order No.
125	80	40	4	10.000	◇	10156560
125	100	40	4	10.000	◇	10156599
125	130	40	4	10.000	◇	10156606
125	150	40	4	10.000	◇	10156608
125	180	40	4	10.000	◇	10156609
125	230	40	4	10.000	◇	10156613

Can be re-sharpened once. For spare knives please see chapter Knives.

### Spare parts

Denomination	Dimension mm	DT	Order No.
Clamping wedge	80x17,9x12	◇	10157242
Clamping wedge	100x17,9x12	◇	10157243
Clamping wedge	130x17,9x12	◇	10157244
Clamping wedge	150x17,9x12	◇	10157245
Clamping wedge	180x17,9x12	◇	10157246
Clamping wedge	230x17,9x12	◇	10157247
Threaded pin	M12x20	◇	10157171
Sliding bar key	SW6	◇	40005681

## Planing cutter head

### Powerlock with centrifugal clamping



<b>APPLICATION:</b>	For pre and finish planing
<b>MATERIAL:</b>	Hard and soft wood
<b>MASCHINE:</b>	Weinig Powermat
<b>DESIGN:</b>	Steel body, with HSK 85 holder for Weinig Powerlock system.
<b>TOOTH:</b>	HS TOK system Centrolock
<b>FEED:</b>	MEC

**33030**

D mm	B mm	d mm	Z	n (max) min <sup>-1</sup>	DT	Order No. rhs	Order No. lhs
93	60	HSK 63WE	2	12.000	◇	10157280	10157281
93	80	HSK 63WE	2	12.000	◇	10157282	10157283
93	100	HSK 63WE	2	12.000	◇	10157284	10157285
93	130	HSK 63WE	2	12.000	◇	10157286	10157287
93	150	HSK 63WE	2	12.000	◇	10157288	10157289
93	170	HSK 63WE	2	12.000	◇	10157290	10157291
93	190	HSK 63WE	2	12.000	◇	10156806	10156807
93	210	HSK 63WE	2	12.000	◇	10157292	10157293
93	240	HSK 63WE	2	12.000	◇	10157294	10157295

Can be re-sharpened once. For spare knives please see chapter Knives.

### Spare parts

Denomination	Dimension mm	DT	Order No.
Clamping wedge	60x17,9x12	◇	10157230
Clamping wedge	80x17,9x12	◇	10157242
Clamping wedge	100x17,9x12	◇	10157243
Clamping wedge	130x17,9x12	◇	10157244
Clamping wedge	150x17,9x12	◇	10157245
Clamping wedge	170x17,9x12	◇	10157239
Clamping wedge	190x17,9x12	◇	10157184
Clamping wedge	210x17,9x12	◇	10157240
Clamping wedge	240x17,9x12	◇	10157241
Threaded pin	M12x20	◇	10157171
Sliding bar key	SW6	◇	40005681



## Planing cutter head

### Spiral planing cutter head

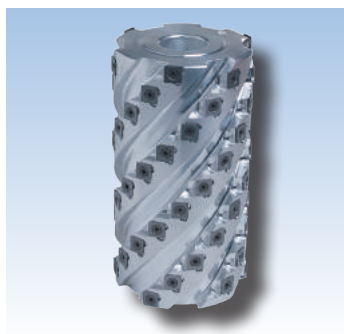

<b>APPLICATION:</b>	For pre planing
<b>MATERIAL:</b>	Hard and soft wood
<b>MACHINE:</b>	Four-sided profile cutting and planing machine
<b>DESIGN:</b>	Tool body made of light metal. Knife with radius for tear-free cuts and smooth surface. Z3 with 6 helices, therefore step-free overlaps.
<b>TOOTH:</b>	HW

# 33010

D mm	B mm	d mm	Z	n (max) min <sup>-1</sup>	DT	Order No.
125	100	40	3 (30)	10.000	◇	10156621
125	130	40	3 (36)	10.000	◇	10156623
125	180	40	3 (48)	10.000	◇	10156625
125	230	40	3 (60)	10.000	◇	10156627

Available with axial angle on demand.  
Can be mounted on Powerlock holder - see page 305.

#### Spare parts

Denomination	Dimension mm	DT	Order No.
HW TOK	15x15x2,5 Z4	◇	10149346
Torx countersunk screw form N	M5x13	◇	10110740

## Bevel cutter

### Swivel cutter head



<b>APPLICATION:</b>	Jointing, bevelling
<b>MATERIAL:</b>	Hard and soft wood, wood-based panel material
<b>MACHINE:</b>	Milling machine and sizing machine
<b>DESIGN:</b>	Tool body made of light metal. Infinitely swivelling (+/-90°) Rebate cutting with additional disc possible.
<b>TOOTH:</b>	HW
<b>FEED:</b>	MAN

# 33010

D mm	B mm	d mm	Z	d (max) mm	n (max) min <sup>-1</sup>		DT	Order No.
160	50	30	2	up to 50	5.000 - 6.000	Steel	◇	10111453
200	80	30	2	up to 50	4.500 - 5.800	Alu	◇	10105274

Additional disc for rebate cutting available on demand.

#### Spare parts 10111453 (B=50)

Denomination	Dimension mm	DT	Order No.
HW TOK	50x12x1,5 Z2	◇	10009474
Clamping wedge	48	◇	10110635
Swivelling element	to B = 50	◇	10110639

#### Spare parts 10105274 (B=80)

Denomination	Dimension mm	DT	Order No.
HW TOK	80x13x2,2 Z2	◇	10009478
Clamping wedge	78	◇	10110637
Swivelling element	to B = 80	◇	10112938

## Bevel cutter

### Bevel cutter 45°, HS and TOK

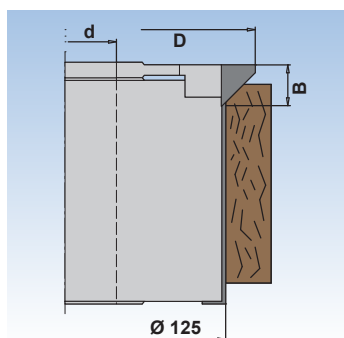

<b>APPLICATION:</b>	For chamfering combined with a planer cutter head
<b>MATERIAL:</b>	HS: Soft wood WP: Hard and soft wood
<b>DESIGN:</b>	HS Tipped cutters Bevel cutter TOK: Cutter head, steel body Weinig Standard
<b>TOOTH:</b>	HS HW TOK Z4
<b>FEED:</b>	MEC

# 33030

#### HS bevel cutter

D mm	B mm	d mm	Z	n (max) min <sup>-1</sup>	rhs/lhs	Order No.
148	16	40	2	depends on the planer head	rhs	10015215
148	16	40	2	depends on the planer head	lhs	10015213

Available in HW as well.

#### WP Bevel cutter

D mm	B mm	d mm	Z	n (max) min <sup>-1</sup>	rhs/lhs	Order No.
145	15	40	4	depends on the planer head	rhs	10026459
145	15	40	4	depends on the planer head	lhs	10031981

#### Spare parts

Denomination	Dimension mm	Order No.
HW TOK	15x15x2,5 Z4	40007373
Countersunk screw DIN 7991 T	M5x6,1	40005305

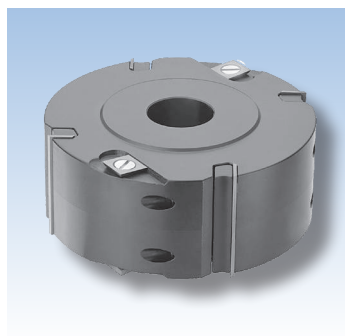

<b>APPLICATION:</b>	Jointing and rebating
<b>MATERIAL:</b>	Hard and soft wood, wood-based panel material
<b>MACHINE:</b>	Milling machine and sizing machine
<b>DESIGN:</b>	Cutter head, steel body, without axial angle
<b>TOOTH:</b>	HW TOK Z2 HW spurs Z4
<b>FEED:</b>	MAN

## 33010

D mm	B mm	d mm	Z	DT		Order No.
125	30	30	2 / V4	◇	Alu	10156691
125	50	30	2 / V4	◇	Steel	10156697
125	50	30	4 / V4	◇	Steel	10156698
125	60	30	2 / V4	◇	Steel	10010244

### HW TOK

Allocation	Dimension mm	DT	Order No.
for 10156691	30x12x1,5 Z2	◇	10009464
for 10156697, 10156698	50x12x1,5 Z2	◇	10009474
for 10010244	60x12x1,5 Z2	◇	10009476
Spur	14x14x2 Z4	◇	10009453

### Clamping wedge

Allocation	Dimension mm	DT	Order No.
for 10156691	28 mm	◇	10023051
for 10156697, 10156698	48 mm	◇	10017268
for 10010244	58 mm	◇	10017269

### Spare parts

Denomination	Dimension mm	DT	Order No.
Countersunk screw DIN 963	M5x8	◇	40001969
Threaded pin	M6x16	◇	40001998
Allen key	SW3	◇	10006089
Setting gauge	0,55 mm	◇	10019459

## Grooving cutter

### HW Lamello grooving cutter

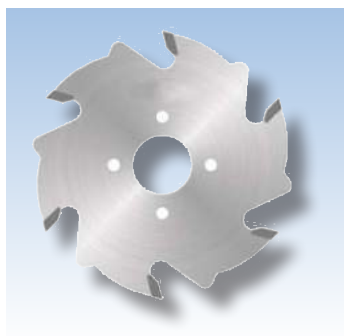

<b>APPLICATION:</b>	Grooving for lamella plates
<b>MATERIAL:</b>	Hard and soft wood, wood-based panel material
<b>MACHINE:</b>	Power tools
<b>DESIGN:</b>	Tipped cutters
<b>TOOTH:</b>	HW
<b>FEED:</b>	MAN

**33010**

D mm	B mm	d mm	Z	NL	n (max) min <sup>-1</sup>	Order No.
100	3.97	22	2 / V4	4/4,5/36	7.600 - 13.300	10156629

## Grooving cutter

### TOK Lamello grooving cutter

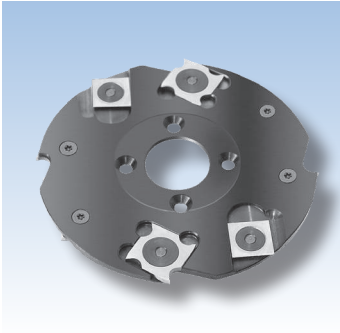

<b>APPLICATION:</b>	Grooving for lamella plates
<b>MATERIAL:</b>	Wood and wood-based material with and without coating
<b>MACHINE:</b>	Power tools
<b>DESIGN:</b>	TOK, steel body, top and side cutting.
<b>TOOTH:</b>	HW TOK Z4 , HW spurs Z4
<b>FEED:</b>	MAN

**33010**

D mm	B mm	d mm	Z	n (max) min <sup>-1</sup>	DT	Order No.
100	3.97	22	4 / V4	7.700 - 13.200	◇	10156726

#### Spare parts

Denomination	Dimension mm	DT	Order No.
HW TOK	18x18x1,95 Z4	◇	10009494
HW spur	14x14x1,2 Z4	◇	10009452
Nut for strobes	1,95 M4x0,5 D=11,8	◇	10157164
Nut for spurs	1,20 M4x0,5 D=9,8	◇	10006105
Torx screw	M4x0,5x3,2		40006392
Sliding bar key	T 9	◇	40004177
Setting gauge		◇	10020189

## Grooving cutter

### Lamello grooving cutter



<b>APPLICATION:</b>	For lamello grooves
<b>MATERIAL:</b>	Wood and panel material with and without coating
<b>MACHINE:</b>	Portable machines
<b>TOOTH:</b>	Clustered teeth, HW

**33010**

With hub (spacer 55 / 22 x 0.5)

D mm	B mm	d mm	Z	Order No.
100	3.97	22	12	235110022

### Grooving cutter for Elu-Doublo DS140 [2353]

Without hub

D mm	B mm	d mm	Z	Order No.
100	3.97	22	12	235310022

# Grooving cutter

## Resin pocket cutter



<b>APPLICATION:</b>	For cutting resin pockets and damages
<b>MATERIAL:</b>	Solid wood
<b>MACHINE:</b>	Power tools
<b>DESIGN:</b>	Tipped cutters
<b>TOOTH:</b>	HW
<b>FEED:</b>	MAN

**35010**

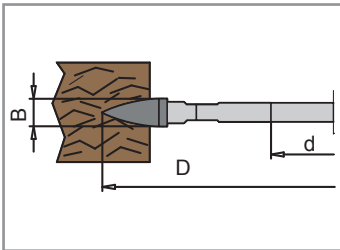

D mm	B mm	d mm	Z	n (max) min <sup>-1</sup>	DT	Order No.
100	8	22	4	7.600 - 13.400	◇	10156729



## Grooving cutter

### TOK cutter for guiding rebate

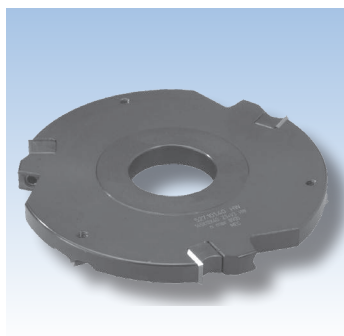

<b>APPLICATION:</b>	To be combined with a planing cutter head
<b>MATERIAL:</b>	Hard and soft wood
<b>DESIGN:</b>	Cutter head with TOK and spurs
<b>TOOTH:</b>	HW
<b>FEED:</b>	MEC

# 33010

D mm	B mm	d mm	Z	n (max) min <sup>-1</sup>	DT	Order No.
145	12	40	2 / V2	11.000	◇	10156620

### Spare parts

Denomination	Dimension mm	DT	Order No.
HW TOK	12x12x1,5 Z4	◇	10009450
Clamping wedge	10,5	◇	10028146
Threaded pin DIN 915	M 8x16	◇	40002009
HW spur	14x14x2,0 Z4	◇	10009453
Countersunk screw DIN 7991	M 5x6	◇	40001968
Sliding bar key	SW 4	◇	40004852

# Grooving cutter

## TOK adjustable grooving cutter

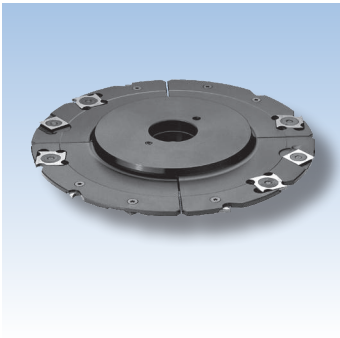

<b>APPLICATION:</b>	Cutting grooves on circular bench saws and milling machines
<b>MATERIAL:</b>	Hard and soft wood
<b>MACHINE:</b>	Bench-mounted milling machines
<b>DESIGN:</b>	TOK design with scrapers and spurs on both sides. Body made of light metal. Grooving depth t (max.) 100 mm.
<b>TOOTH:</b>	HW TOK Z 2 HW spurs Z4
<b>FEED:</b>	MAN

**33010**

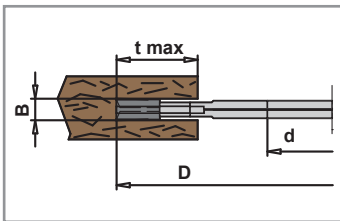

D mm	B mm	d mm	Z	d (max) mm	n (max) min <sup>-1</sup>	DT	Order No.
250	8-15	30	4 / V4	up to 50	3.000 - 5.000	◇	10157337

### Spare parts

Denomination	Dimension mm	DT	Order No.
HW spurs	14x14x2	◇	10009453
Clamping wedge	6,5 mm	◇	10157160
Screw	M5x6	◇	10006092
Clamping screw	M5x16	◇	40001987
Screw	M5x9	◇	10006093
Key	SW2,5	◇	10006088
Sliding bar key	T9	◇	40004177
Setting gauge	0,25 mm	◇	10157167

For turn-over knives see chapter Knives.

## Grooving cutter

### TOK grooving cutter

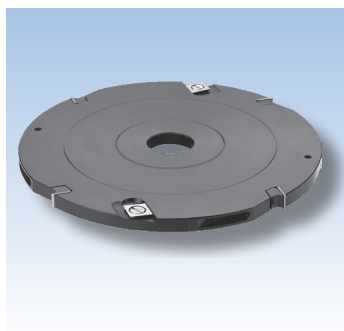

<b>APPLICATION:</b>	For grooving along and across the grain
<b>MATERIAL:</b>	Hard and soft wood, wood-based panel material
<b>MACHINE:</b>	Milling machine and sizing machine
<b>DESIGN:</b>	B 4-6mm: Steel body B 8-12mm: aluminium body
<b>TOOTH:</b>	HW TOK Z 2 / Z 4 HW spurs Z4
<b>FEED:</b>	MAN

# 33010

D mm	B mm	d mm	Z	t (max) mm	DT	Order No. cutter	Order No. clamping wedge
125	4	30	4+4	37	◇	10156888	
125	5	30	4+4	37	◇	10156889	
125	6	30	4+4	37	◇	10156890	
125	8	30	4+4	37	◇	10156891	10157160
125	10	30	4+4	37	◇	10156892	10157162
125	12	30	4+4	37	◇	10156893	10157163
150	4	30	4+4	49	◇	10156895	
150	5	30	4+4	49	◇	10156896	
150	6	30	4+4	49	◇	10156897	
150	8	30	4+4	49	◇	10156898	10157160
150	10	30	4+4	49	◇	10156899	10157162
150	12	30	4+4	49	◇	10156900	10157163

### Spare knives / Spare parts

Denomination	Dimension mm	DT	Order No.
Spurs for B = 4-6 mm	14x14x1,2	◇	10009452
Spurs for B = 8-12 mm	14x14x2,0	◇	10009453
TOK for B = 4 mm	18x18x1,95	◇	10009494
TOK for B = 5 mm	18x18x2,45	◇	10009495
TOK for B = 6 mm	18x18x2,95	◇	10009496
TOK for B = 8 mm	7,5x12x1,5	◇	10009449
TOK for B = 10 mm	9,6x12x1,5	◇	10009480
TOK for B = 12 mm	11,6x12x1,5	◇	10009483
Torx nut	D=9,8	◇	10006105
Torx nut	D=11,8	◇	10157164
Countersunk screw DIN 963	M5x8	◇	40001969
Threaded pin	M6x16	◇	40001998
Allen key	SW3	◇	10006089
Setting gauge	0,55 mm	◇	10019459

## HW Adjustable grooving cutter

With spacers in 0,1 mm increments



<b>APPLICATION:</b>	For grooving along and across the grain
<b>MATERIAL:</b>	Wood and panel material with and without coating
<b>MACHINE:</b>	Milling machine and sizing machine
<b>DESIGN:</b>	HW-tipped with wipers, flat, spurs on top and bottom, top and side cutting.
<b>TOOTH:</b>	HW
<b>FEED:</b>	MAN

### 33010

#### Plane tool body

D mm	B mm	d mm	Z	d (max) mm	n (max) min <sup>-1</sup>	t (max)	Order No.
120	1,8-3,4	30	6+6	30	6.000 - 12.000	12	10001957
120	2,2-4	30	6+6	30	6.000 - 12.000	15	10001958
140	2,2-4	30	6+6	30	6.000 - 12.000	15	10001960

#### Stepped tool body

D mm	B mm	d mm	Z	d (max) mm	n (max) min <sup>-1</sup>	t (max)	DT	Order No.
140	2,5-4,8	30	4 / V4	up to 50	5.500 - 9.500	15	◇	10023859
150	4-7,5	30	4 / V4	up to 50	5.100 - 9.000	35	◇	10009619
150	7,5-14	30	4 / V4	up to 50	5.100 - 9.000	35	◇	10009622
160	10-19	30	4 / V4	up to 50	4.800 - 8.300	40	◇	40004980



## Grooving cutter

### Adjustable TOK grooving cutter with spacers



<b>APPLICATION:</b>	For grooving along and across the grain
<b>MATERIAL:</b>	Hard and soft wood, wood-based panel material
<b>DESIGN:</b>	Steel body
<b>TOOTH:</b>	HW TOK Z 2 / Z 4 / HW spurs Z4
<b>FEED:</b>	MAN

# 33010

D mm	B mm	d mm	Z	d (max) mm	n (max) min <sup>-1</sup>	t (max)	DT	Order No.
160	8,0-15	30	4 / V4	50	4.800 - 8.300	32	◇	10156634
160	12,6-24	30	4 / V4	50	4.800 - 8.300	32	◇	10156636
180	8-15	30	4 / V4	50	4.300 - 7.400	38	◇	10156637
180	12,6-24	30	4 / V4	50	4.300 - 7.400	38	◇	10156638

### Spare parts

Denomination	Dimension mm	DT	Order No.
HW TOK for B = 8,0 - 15	7,5x12x1,5	◇	10009449
HW TOK for B =12,6 - 24	12x12x1,5	◇	10009450
Clamping wedge for B = 8,0 - 15		◇	10157229
Clamping wedge for B =12,6 - 24		◇	10028146
HW spur	14x14x2	◇	10009453
Threaded pin DIN 915	M8x16	◇	40002009
Threaded pin	M5x16	◇	40001987
Countersunk screw DIN 963	M5x8	◇	40001969
Countersunk screw DIN 963	M5x6	◇	10119194
Sliding bar key	SW4	◇	40004852
Key	SW 2,5	◇	10006088
Set of rings for B = 8-15 mm		◇	10157250
Set of rings for B = 12,6 - 24 mm		◇	10157251

## Radius cutter

### TOK quarter round cutter

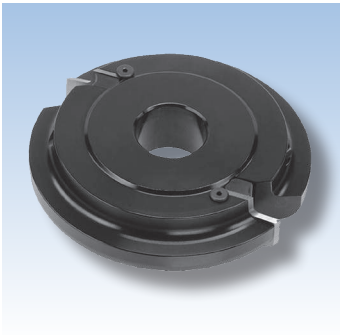

<b>APPLICATION:</b>	Rounding
<b>MATERIAL:</b>	Hard and soft wood, wood-based panel material
<b>DESIGN:</b>	Aluminium tool body Size 1: suitable for R3 - R10 Size 2: suitable for R12 - 20 D0 = 100 mm
<b>TOOTH:</b>	HW profile knives
<b>FEED:</b>	MAN

**35010**

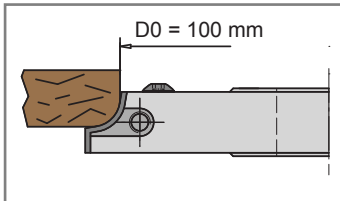

D mm	B mm	d mm	Z	d (max)	DT	Order No.
120	20	30	2	40	◇	10156730
140	30	30	2	40	◇	10156731

#### Spare parts

Denomination	Dimension mm	DT	Order No.
HW profile plate for 10156730	20x25x2 size.1 R8	◇	10157108
HW profile plate for 10156731	30x35x2 size.2 R12	◇	10157115
Clamping wedge for 10156730	17,5 mm for size1	◇	10157128
Clamping wedge for 10156731	26 mm for size 2	◇	10157129
Screw	M4x6	◇	10157165
Threaded pin	M6x16	◇	40001998
Allen key	SW3	◇	10006089

## Profile cutter

Universal safety cutter head, 40 mm kerf

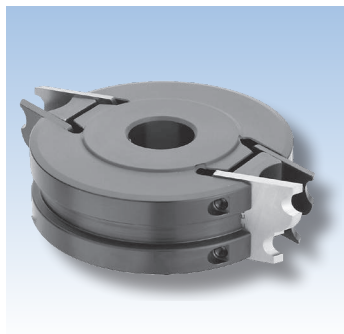

<b>APPLICATION:</b>	For jointing, rebating and profiling
<b>MATERIAL:</b>	Hard and soft wood
<b>DESIGN:</b>	Steel body For profiling depths of up to 17 mm, with a flying circle of 133 mm max.
<b>TOOTH:</b>	SP or HS
<b>FEED:</b>	MAN

### 35030

D mm	B mm	d mm	Z	d (max) mm	n (max) min <sup>-1</sup>	DT	Order No.
93	40	30	2	up to 31,75	6.000 - 9.000	◇	10023096

Standard and special profile knife catalogue available for downloading under: [www.ake.de](http://www.ake.de).

## Profile cutter

Universal safety cutter head, 40 / 50 mm kerf

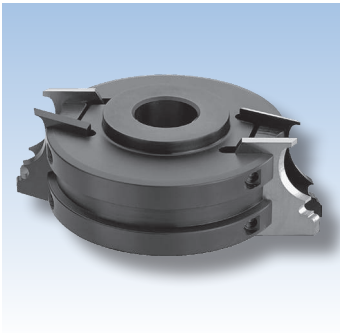

<b>APPLICATION:</b>	For jointing, rebating and profiling
<b>MATERIAL:</b>	Hard and soft wood
<b>DESIGN:</b>	Steel body for profile knives with 40 and 50 mm kerf. For profile depths up to 17 mm, with a flying circle of 150 mm max.
<b>TOOTH:</b>	SP or HS
<b>FEED:</b>	MAN

35030

D mm	B mm	d mm	Z	d (max)	n (max) min <sup>-1</sup>	DT	Order No.
114	40 / 50	30	2	up to 31,75	5.100 - 7.900	◇	40015575

Standard and special profile knife catalogue available for downloading under: [www.ake.de](http://www.ake.de).



## Profile cutter

Universal safety cutter head, 60 - 80 mm kerf

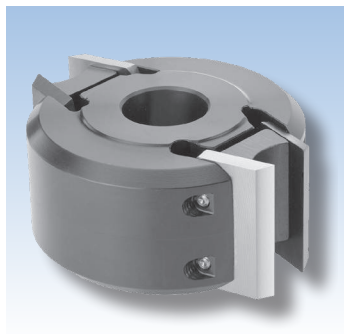

<b>APPLICATION:</b>	For profiling
<b>MATERIAL:</b>	Hard and soft wood
<b>DESIGN:</b>	Steel body for profile knives with 60 and 80 mm kerf. For profile depths up to 30 mm, with a flying circle of 182 mm max.
<b>TOOTH:</b>	HS
<b>FEED:</b>	MAN

### 35030

D mm	B mm	d mm	Z	d (max)	DT	Order No.
110	60 / 80	30	2	up to 40	◇	10156640

Standard and special profile knife catalogue available for downloading under: [www.ake.de](http://www.ake.de).

## Profile cutter

### Serrated back profile cutter head



<b>APPLICATION:</b>	For profiling
<b>MATERIAL:</b>	Hard and soft wood, wood-based panel material
<b>DESIGN:</b>	Steel body with high-precision serration to hold profile knife blanks of 8 or 10 mm thickness.
<b>TOOTH:</b>	HS, ST, HW, HW super pack
<b>FEED:</b>	MEC

**35030**

D mm	B mm	d mm	Z	n (max) min <sup>-1</sup>	DT	Order No. cutter	Order No. clamping wedge	Order No. dummy piece
122	40	40	2	9.000	◇	10156582	40011422	10110783
122	60	40	2	9.000	◇	10156586	10110631	10110785
122	80	40	2	9.000	◇	10156589	10110393	10110786
122	40	40	4	9.000	◇	10156590	40011422	10110783
122	60	40	4	9.000	◇	10156591	10110631	10110785
122	80	40	4	9.000	◇	10156594	10110393	10110786
122	100	40	4	9.000	◇	10156595	40011650	40011604
122	130	40	4	9.000	◇	10156596	10110395	40015377
122	150	40	4	9.000	◇	10156597	10110396	10110787
122	180	40	4	9.000	◇	10156598	10110638	10110788
122	230	40	4	9.000	◇	10156607	10110398	40012096
137	40	50	4	9.000	◇	10156612	40011422	10110783
137	60	50	4	9.000	◇	10156614	10110631	10110785
137	80	50	4	9.000	◇	10156615	10110393	10110786
137	100	50	4	9.000	◇	10156616	40011650	40011604
137	130	50	4	9.000	◇	10156617	10110395	40015377
137	150	50	4	9.000	◇	10156619	10110396	10110787
137	180	50	4	9.000	◇	10156622	10110638	10110788

Tool body without knives.  
For knife blanks see chapter knives.

#### Spare parts

Denomination	Dimension mm	DT	Order No.
Threaded pin	M12x20	◇	10157171
Sliding bar key	SW6	◇	40005681

## Profile cutter

### Profile cutter head Powerlock



Fig.: Z=2

<b>APPLICATION:</b>	For profiling
<b>MATERIAL:</b>	Hard and soft wood, wood-based panel material
<b>DESIGN:</b>	Steel body with HSK 85 holder for Weinig Powerlock system. With high-precision serration to hold profile knife blanks of 8 or 10 mm thickness.
<b>TOOTH:</b>	HS, ST, HW, HW super pack
<b>FEED:</b>	MEC

# 35030

D mm	B mm	d mm	Z	n (max) min <sup>-1</sup>	DT	Order No. rhs	Order No. lhs	Order No. Clamping wedge
90	60	HSK 63WE	2	12.000	◇	10156783	10156796	10157181
90	80	HSK 63WE	2	12.000	◇	10156792	10156801	10157182
90	100	HSK 63WE	2	12.000	◇	10156795	10156802	10157183
90	130	HSK 63WE	2	12.000	◇	10157212	10157216	10157222
90	150	HSK 63WE	2	12.000	◇	10157217	10157219	10157223
90	170	HSK 63WE	2	12.000	◇	10157254	10157253	10157224
90	190	HSK 63WE	2	12.000	◇	10157256	10157255	10157225
90	210	HSK 63WE	2	12.000	◇	10157258	10157257	10157227
90	240	HSK 63WE	2	12.000	◇	10157260	10157259	10157228
90	60	HSK 63WE	4	12.000	◇	10157264	10157261	10157181
90	80	HSK 63WE	4	12.000	◇	10157262	10157265	10157182
90	100	HSK 63WE	4	12.000	◇	10157266	10157263	10157183
90	130	HSK 63WE	4	12.000	◇	10157268	10157267	10157222
90	150	HSK 63WE	4	12.000	◇	10157270	10157269	10157223
90	170	HSK 63WE	4	12.000	◇	10157272	10157273	10157224
90	190	HSK 63WE	4	12.000	◇	10157274	10157275	10157225
90	210	HSK 63WE	4	12.000	◇	10157276	10157277	10157227
90	240	HSK 63WE	4	12.000	◇	10157278	10157279	10157228

Tool body without knives.

For knife blanks see chapter knives.

### Spare parts

Denomination	Dimension mm	DT	Order No.
Threaded pin	M12x20	◇	10157171
Sliding bar key	SW6	◇	40005681

# Profile cutter

## Multi - TOK profile cutter

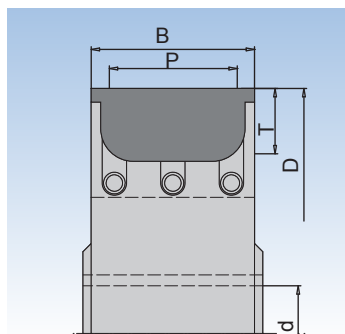

<b>APPLICATION:</b>	For profiling
<b>MATERIAL:</b>	Hard and soft wood, wood-based panel material
<b>DESIGN:</b>	Steel body with clamping elements. For holding HW special profile knives with support plate.
<b>TOOTH:</b>	HW profile knives
<b>FEED:</b>	MEC

### 35010

D mm	B mm	d mm	Z	d (max) mm	P	T	Order No.
<b>For mechanical feed</b>							
160	40	35	3	up to 50	31	20	10018203
160	60	35	3	up to 50	51	25	10018202
180	60	35	4	up to 50	48	22	10028692
180	80	35	4	up to 50	60	30	10107420
<b>For manual feed</b>							
170	50	30	3	up to 50	41	18	10107426

Knives and support plates will be profiled according to customer demand.

Profile drawings or wood samples are required.

Special profile knives. 1 packing unit = 10 pcs.

#### Spare parts 10018203 (MEC)

Denomination	Dimension (B) mm	Order No.
Blank	40x35x2,0 Z1	33009263
Clamping wedge	38	10016489
Threaded pin	M8x16	40002009
Support plate		10019297
Stop screw	M5	40002938

#### 10018202, 10028629 (MEC)

Dimension (B) mm	Order No.
60x40x2,0 Z1	10014340
58	10016488
M8x16	40002009
	10023992
M5	40002938

#### Spare parts 10107420 (MEC)

Denomination	Dimension (B) mm	Order No.
Blank	80x45x2,5 Z1	10023442
Clamping wedge	84	10021472
Threaded pin	M8x35	40002014
Support plate		33009948
Stop screw	M5	40002938
Deflector		

#### 10107426 (MAN)

Dimension (B) mm	Order No.
50x45x2,0 Z2	10017983
48	10018714
M8x16	40002009
	40003550
M5	40002938
	33010961

## Profile cutter

### TOK tongue and groove cutter



<b>APPLICATION:</b>	For the production of tongue and groove profiles
<b>MATERIAL:</b>	Hard and soft wood, wood-based panel material
<b>DESIGN:</b>	Steel body. By means of combining different tools a variety of profiles can be produced. max 8.000 rpm
<b>TOOTH:</b>	HW TOK Z 2 / Z 4 HW spurs Z 4
<b>FEED:</b>	MEC

# 35010

D mm	B mm	d mm	Z	n(max) min <sup>-1</sup>	DT	Order No.
140	15	60	4	8.000	◇	10156628
124	12	60	2	8.000	◇	10156683
140	15	60	4	8.000	◇	10156681
140	20	60	4	8.000	◇	10156685
141	20	60	4	8.000	◇	10156686
140	20	60	4	8.000	◇	10156687
154,4	11,6	60	2	8.000	◇	10156688
154,4	11,6	60	2	8.000	◇	10156689
171	15	60	4	8.000	◇	10156690
159	20	60	4	8.000	◇	10156692

Denomination	Dimension mm	DT	Order No.
HW TOK	11,6x12x1,5	◇	10009483
HW TOK	12x12x1,5	◇	10009450
HW TOK	15x12x1,5	◇	10009455
HW TOK	20x12x1,5	◇	10009457
Clamping wedge for 2/7/8		◇	10157173
Clamping wedge for 1/3/9		◇	10157177
Clamping wedge for 4/5/6/10		◇	10157175
Spur	14x14x2	◇	10009453
Threaded pin for 2/9	M8x16	◇	40002009
Threaded pin	M8x12	◇	40002007
Countersunk screw DIN 963	M5x8	◇	40001969
Grooving knife	25x13x4	◇	10157178
Screw for grooving knife	M5x13	◇	10157177
Sliding bar key	SW4	◇	40004852
Allen key	SW3	◇	10006089
Edge knife 45°	22x16x5	◇	10109412

## Panel raising cutter

### TOK panel raising cutter

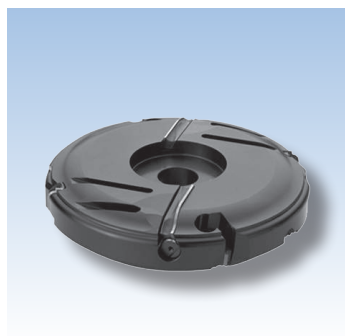

Type A

**35010**

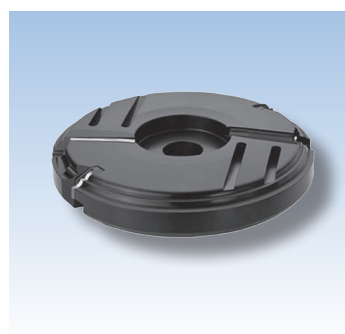

Type B

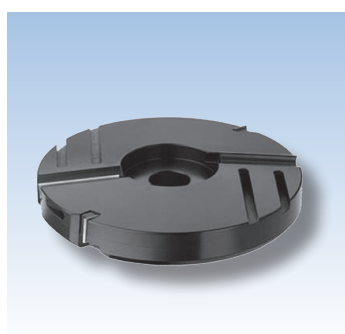

Type C

<b>APPLICATION:</b>	For the production of panel raising profiles on furniture doors
<b>MATERIAL:</b>	Hard and soft wood, wood-based panel material
<b>DESIGN:</b>	Tool body made of light metal with profile knives and panel raising knives. Applied for right-hand rotation, top.
<b>TOOTH:</b>	HW profile knives
<b>FEED:</b>	MAN

D mm	B mm	d mm	Z	Design	DT	Order No.
200	35	30	2+2	Type A	◇	10156733
200	35	30	2+2	Type B	◇	10156736
200	35	30	2+2	Type C	◇	10156737

#### Spare knives

Denomination	Dimension mm	DT	Order No. knives	Order No. clamping wedge
Profiled TOK	20x12x1,5 Type A	◇	10157117	10157130
Profiled TOK	20x23x2,0 Type B	◇	10157118	10157134
Profiled TOK	20x12x1,5 Type C	◇	10157119	10157155
Profiled TOK	60x12x1,5 Type A	◇	10157125	10157132
Profiled TOK	50x12x1,5 Type B	◇	10157126	10157136
Profiled TOK	60x12x1,5 Type C	◇	10157127	10157156

#### Spare parts

Denomination	Dimension mm	DT	Order No.
Stop screw for panel raising cutter	M6x10	◇	10157166
Threaded pin	M6x16	◇	40001998
Allen key	SW3	◇	10006089

## Glue joint cutter

### TOK glue joint cutter

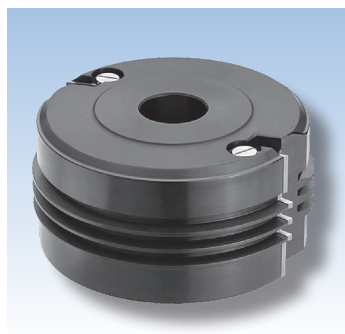

<b>APPLICATION:</b>	For glue joints. The profile and the counter profile are being cut with the same tool by changing the reference face.
<b>MATERIAL:</b>	Hard and soft wood
<b>DESIGN:</b>	Steel body with profile knives. Adjustable profile seat due to adjustable lateral stop screws.
<b>TOOTH:</b>	HW TOK Z 2
<b>FEED:</b>	MAN

35010

D mm	B mm	d mm	Z	Profile height = minimum wood thickness	DT	Order No.
130	50	30	2	16	◇	10156745
130	60	30	2	24	◇	10156747
130	80	30	2	32	◇	10156748

Glue joint cutter for longitudinal glueing available on demand.

### Spare knives

Denomination	Dimension mm	DT	Order No. Knives	Order No. Clamping wedges
for B = 50	50x24x2	◇	10157120	10157157
for B = 60	60x24x2	◇	10157123	10157158
for B = 80	80x24x2	◇	10157124	10157159

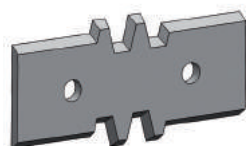

Fig: for B = 50 mm

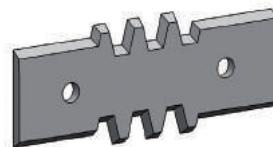

Fig: for B = 60 mm

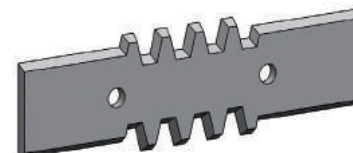

Fig: for B = 80 mm

### Spare parts

Denomination	Dimension mm	DT	Order No.
Threaded pin	M6x16	◇	40001998
Allen key	SW3	◇	10006089

## Edge trimming cutter

HW cutter for flush milling

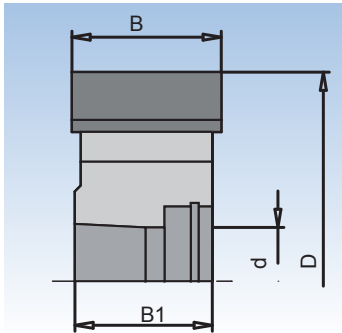

**35010**

<b>APPLICATION:</b>	For pre-cutting solid wood edge bands on keyed aggregates.
<b>MATERIAL:</b>	All types of edge banding materials, especially suitable for veneer and solid wood, limited suitability for PP, PVS, ABS, melamine.
<b>MACHINE:</b>	Sizing machines and edge banding machines
<b>DESIGN:</b>	Edge cutter with HSK 25 holder and clamping screw. This tool is designed with a small axial angle in order to avoid the edge band being pulled downward.
<b>TOOTH:</b>	HW; the tool can be re-sharpened. However, re-sharpening is not recommended, because the tracing rollers have to be adjusted to the new, smaller tool diameter after re-sharpening.
<b>FEED:</b>	MEC

D mm	B mm	B1 mm	d mm	Z	n (max) min-1	rhs/lhs	DT	Order No.
70	25	23	HSK 25	4	24.000	rhs	◇	10025866
70	25	23	HSK 25	4	24.000	lhs	◇	10025867

For DP edge cutters see chapter DP-Tools.



## Safety Information for Tools

Please read prior to installation and operation

### The tools conform to standard DIN-EN 847-1/2.

Tools should be stored in their original packing or in other appropriate packing. Tools should be stored in dry conditions and away from aggressive substances. There is always the danger of injury due to the sharpness of the tools.

Tools must only be used as designated.

Cutting in feed direction is only permissible for mechanical feed.

The direction of rotation must be observed.

The maximum allowed operating speed must not be exceeded. The machine manufacturer's regulations must be adhered to. If in any doubt please contact AKE Knebel GmbH & Co. KG and/or the machine manufacturer.

Check tools carefully for any signs of damage or defects prior to installation.

Do not install the tool if there are any recognisable defects or damages, if already installed, stop operation immediately, remove tool and mark the tool clearly so that it cannot be installed prior to being checked by a competent person.

Tools showing cracks or similar damages must not be welded or repaired in any form.

Only trained persons with the necessary safety training are allowed to install tools and commence operation of the machine.

Adhere to the operation manual of both the tools and the machine.

Ensure the machine cannot be started.

Tools should only be installed using the clamping mechanism as provided by the machine manufacturer, recommended starting torque should be observed, no other form of installation or tightening is allowed.

The European standard. DIN-EN 1870-1, chapter 3.2.3. is applicable for allocating the appropriate clamping flange diameter to the saw blade diameter. Gloves must be worn, as should close-fitting clothes and ear protection when necessary.

Once the tool has been installed, please ensure that all safety protection devices and the splitting wedge are mounted correctly.

A test run by a trained person must be carried out. Do not reach anywhere near the rotating tool. No uninvolved persons should be near this area.

Do not undertake any adjustments near the rotating tool. Make sure there is no imbalance. The cutting edge of the tool must not come into contact with any other cutting tools, fixing elements or any other parts of the machine

Bore hole reduction rings must be firmly fixed to the tool and must not project over the tool body. Reducing rings must be the correct size to ensure that the tool is fixed correctly.

Never leave the operating machine unattended.

All measures to prevent kick back must be taken, all corresponding devices must be applied.

The working material must be checked for any foreign matter.

The tool must be re-sharpened in due time. Indications for blunt tools are: extreme wear and tear on the cutting edges, broken edges, poor cutting quality and higher energy consumption by the machine. Saw blades with cutting teeth of less than 1 mm must not be used.

Tools must only be re-sharpened by competent personnel and must only be repaired using original parts.

Competent persons are those with corresponding training and experience who have knowledge of the design, designation and safety requirements of the tool.

Tools must only be repaired in compliance with the manufacturers instructions. The following must be observed: the tool design must not be altered, all safety regulations must be adhered to, the applicable tensioning tolerances must be observed.

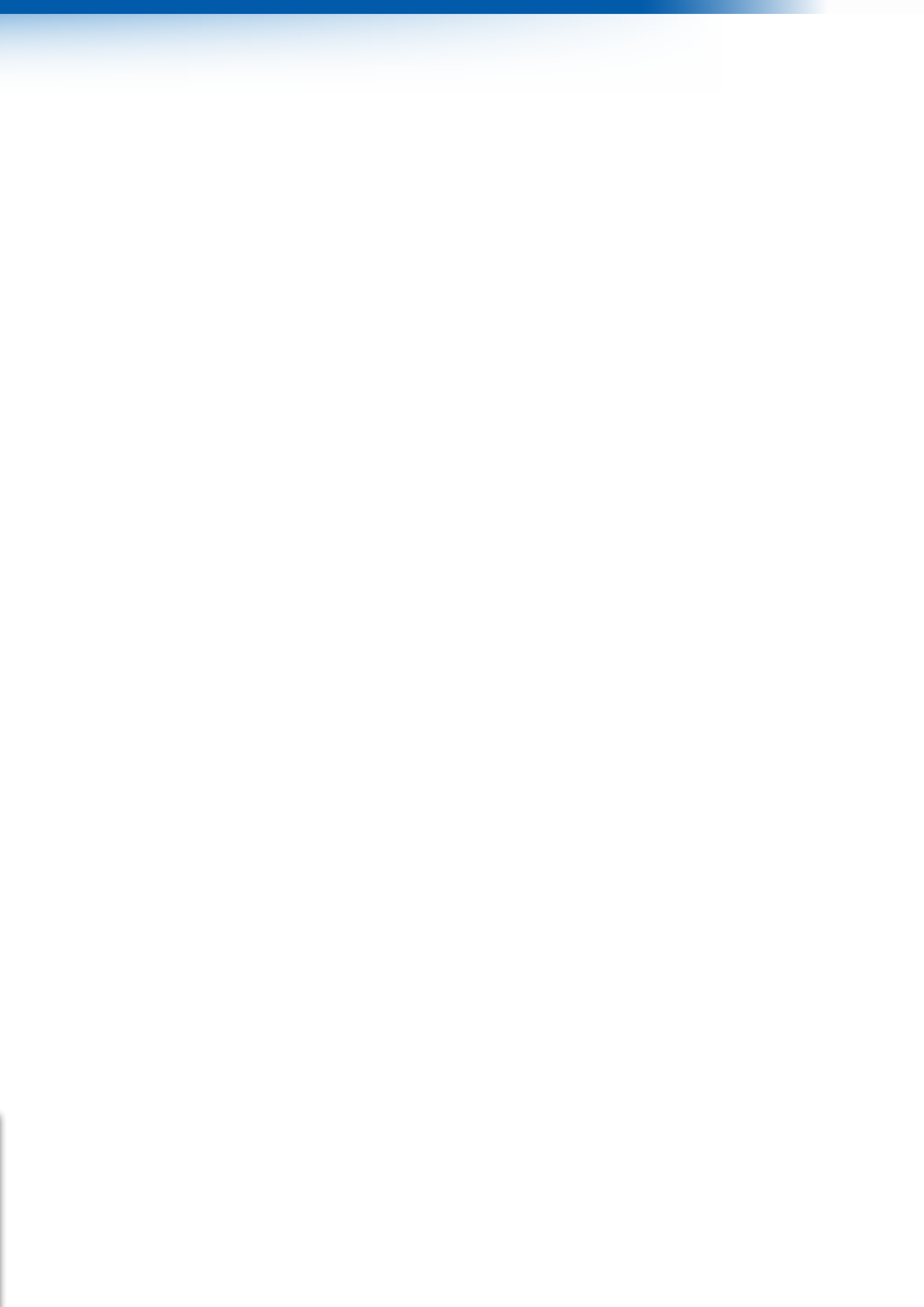

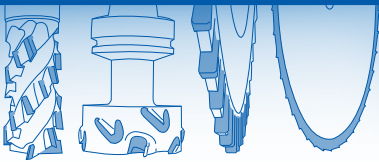

## chip'n chill Cutting 2.0<sup>AKE</sup>



The new age of Cutting 2.0 started in 2013 with the first presentation of the award-winning SuperSilent sizing saw blade. With Cutting 2.0 we always pursue one objective: Creating unique advantages for our customers.

 **AKE Knebel GmbH & Co. KG**

Hölzlestraße 14 + 16  
D-72336 Balingen

Phone: +49 (7433) 261-0  
Fax: +49 (7433) 261-100  
E-Mail: [info@ake.de](mailto:info@ake.de)

 **AKE Knebel GmbH & Co. KG**

Branch office Rietberg  
Konrad-Adenauer-Straße 32  
D-33397 Rietberg

Phone: +49 (5244) 9 20 20  
Fax: +49 (5244) 9 20 280  
E-Mail: [info@ake.de](mailto:info@ake.de)

 **AKE Knebel GmbH & Co. KG**

Branch office Prien  
Am Mühlbach 6  
D-83209 Prien

Phone: +49 (8051) 96 56 78 0  
Fax: +49 (8051) 96 56 78 19  
E-Mail: [info@ake.de](mailto:info@ake.de)

*Please visit us at [www.ake.de](http://www.ake.de)*

Subject to technical changes. Printed in Germany 2017-05-05



[www.ake.de](http://www.ake.de)